



Hardware IFU—TC1012

Version: V1.10 | English

Document Revision History:

Documentation Edition	date	Update content	remarks
V1.00	2023.5.5	Create a document	
V1.10	2024.1.10	Modify the document	

Copyright information

Shanghai TOSUN Technology LTD

6 / 8,4801, Jiading District, Shanghai

In line with the principle of providing better service to users, Shanghai TOSUN Technology LTD (hereinafter referred to as "TOSUN Technology") will present detailed and accurate product information to users as much as possible in this manual. However, since the content of this manual has a certain timeliness, the TOSUN Technology can not fully guarantee the timeliness and applicability of the document at any time period.

The information and data in this user manual are subject to change without notice. In order to get the latest version, please visit the official website of the company or contact the staff. Thank you for your tolerance and support! Any part of this manual shall not be reproduced in any form or in any manner without written permission of TOSUN Technology.

@ Copyright 2023, Shanghai TOSUN Technology LTD. All rights reserved.

catalogue

1. Product profile	1
1.1 Product Overview	1
1.2 Typical applications	1
1.3 Functions and parameters	1
1.3.1 Functional characteristics	1
1.3.2 Technical parameters	2
1.3.3 Electrical parameters	3
1.4 Shipping list	3
2. Hardware interface description	4
2.1 Interface description	4
2.2 LED indicator light instructions	5
3. Quick use	6
3.1 Download and install the TSMaster host computer	6
3.2 Connect devices and configure channels	8
3.3 Message sending	9
3.4 Help with documentation and video teaching	10
3.5 TSMaster API Secondary development	11
3.5.1 Python calls the dynamic library	11
3.5.2 C calls the dynamic library	12
3.5.3 Example of the calling of the interface	12
3.6 Sample Works	15
4. Inspection and maintenance	16
5. Common questions and answers	18
5.1 The line is connected correctly but cannot communicate properly:	18
5.2 Inconvenient message observation and signal filtering:	19
5.3 How to load the database:	20
5.4 How to automatically record the message messages:	20
5.5 How to replay messages (offline and online playback):	21
6. Appendix	22
6.1 CAN 2.0 Standard Frame:	22
6.2 CAN 2.0 Expansion Frame:	23
6.3 matters need attention	24
7. Disclaimer	24

1. Product profile

1.1 Product Overview

TC1012 is a portable, easy to install 1 CANFD / 1 LIN bus to USB interface device launched by The Shanghai TOSUN Technology LTD. CANFD bus rate supports up to 8M bps, LIN bus equipment support rate 0 ~ 20 Kbps, the product adopts high-speed USB2.0 interface and PC connection, Windows system drive-free design makes the device have excellent system compatibility.

With the powerful TSMaster software, it supports loading DBC and ARXML database files, which can easily monitor, analyze, simulate CAN FD / LIN bus data, and can also support UDS diagnosis, ECU brushing, CCP / XCP calibration and other functions.

Can be used for the secondary development API of Windows and Linux, can support various development environments, such as C ++, C #, LabView, Python, etc., convenient integration into various test systems, efficient and easy to use.

1.2 Typical applications

- ✓ Vehicle CAN FD / CAN / LIN bus data collection
- ✓ Domain Controller Test
- ✓ Various automated test systems

1.3 Functions and parameters

1.3.1 Functional characteristics

- ✓ us (microsecond) level hardware message timestamp to meet higher order requirements.
- ✓ High-speed USB2.0 interface, Windows, Linux system drive-free design, with excellent system compatibility.
- ✓ CAN channel DC2500V sequestration.
- ✓ Automotive grade design, support LDF, dbc file, a2l file, blf file, asc file, arxml file.
- ✓ CAN channel port rate 125 Kbps- -1Mbps tunable.
- ✓ The LIN bus master and slave nodes can be software configured.
- ✓ Support for blf, asc format data recording and offline / online playback.
- ✓ UDS diagnosis and CCP and XCP calibration can be supported.
- ✓ Support for the UDS-based Flash Bootloader.

- ✓ Support for information security testing.
- ✓ Support Windows, Linux system secondary development interface.
- ✓ Built-in 120 euro terminal resistance can be used in software configuration.
- ✓ Loadable TSMaster software all charge license

1.3.2 Technical parameters

channel	1 *CAN FD / 1 * LIN
PC terminal interface	High-speed of USB2.0
The CAN / LIN terminal interface	DB9
drive	Windows, Linux system free drive free design, with excellent system compatibility
cache	Hardware cache, each channel sends buffer support to 1000 frames CAN / CANFD
CAN	Support CAN2.0A, B protocol, comply with ISO11898-1 specification, port rate 125 Kbps- 1Mbps
CAN FD	Support for ISO and non-ISO standard CAN FD, port rate 125 Kbps- 8Mbps
LIN	Support LIN 1.3 and 2.0, baud rate 0- 20 Kbps
dispatch list	Support LDF files and run the schedule, or you can configure the schedule yourself
Time stamp accuracy	1us, the hardware message timestamp, to meet the high-order requirements
terminal resistance	Built-in 120 euro terminal resistance can be used in software configuration
Send a message per second *	Maximum of 20,000 frames / s
Receipt of message messages per second *	Maximum of 20,000 frames / s
insulate	CAN channel DC 2500V isolation, electrostatic grade contact discharge \pm 8KV
supply electricity	USB power supply, LIN communication needs external power supply
Case material	plastics
working temperature	-40°C~80°C
Working humidity	10% ~ 90% (no condensation)
work environment	Stay away from the corrosive gases

* Single-channel 1Mbps, 0-byte data domain case

1.3.3 Electrical parameters

Parameter		test condition	least value	representative value	crest value	Unit
working voltage	External input to the DC power supply	Two LIN receiving channels	-	12	-	V
	USB supply electricity	Two CAN delivery channels	5.08	5.10	5.12	V
working current	External input to the DC power supply	Two LIN receiving channels	-	0.01	-	A
	USB supply electricity	Two CAN delivery channels	0.13	0.16	0.20	A
Power	External input to the DC power supply	Two LIN receiving channels	-	0.12	-	W
	USB supply electricity	Two CAN delivery channels	0.67	0.82	1.02	W
CAN joggle	Bus pin pressure resistance	CANH、CAHL	-42	--	42	V
	terminal resistance	Enable terminal resistance	--	120	--	Ω
	Isolation and pressure resistance	The leakage current is less than 1 mA	2500	--	--	VDC
LIN joggle	Bus pin pressure resistance	LINO、LIN1	0	--	24	V
	VBAT voltage		5	12	24	V

1.4 Shipping list

- ✓ TC1012 device



2. Hardware interface description

2.1 Interface description



- USB high-speed 2.0 interface;
- DB9 Male:

DB9 pin definition:

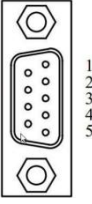
DB9 pin	pin	definition
	PIN2	CANFD_Low
	PIN3	GND
	PIN5	Shield
	PIN7	CANFD_High
	PIN8	LIN
	PIN9	VBAT_LIN

Note: Pin PIN 2 is low CAN, and pin PIN 7 is high CAN, which is consistent with the international standard.

2.2 LED indicator light instructions

Physical picture of the indicator light:

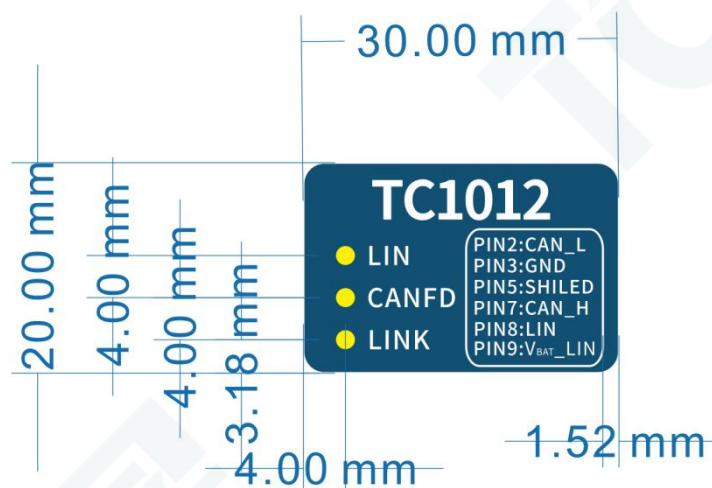

Instructions for indicator light:

pilot lamp	definition
CANFD	The CANFD channel indicator lamp
LIN	The LIN channel indicator light
LINK	Hardware connection indicator light

Description of the indicator light color:

pigment	description
LINK green light	The device hardware is connected
LIN green light	The LIN channel data frame is sent or received correctly
LIN red light	The LIN channel sends or receives incorrect frames, configuration, protocol, or wiring errors
CAN FD green light	CAN FD Channel data frames are sent or received correctly
CAN FD red light	CAN FD The channel sends or receives error frames, configuration, protocol, or wiring errors

Note: The flicker frequency depends on the bus load.

3. Quick use

3.1 Download and install the TSMaster host computer

TSMaster Software download link:

http://www.tosun.tech/TOSUNSoftware/TSMaster_Setup_beta.exe

If not accessible, you can contact the corresponding sales staff or log in to the official website of the same star to get the upper machine, and you can also scan the code to follow the public account to get the download link.



Step 1:

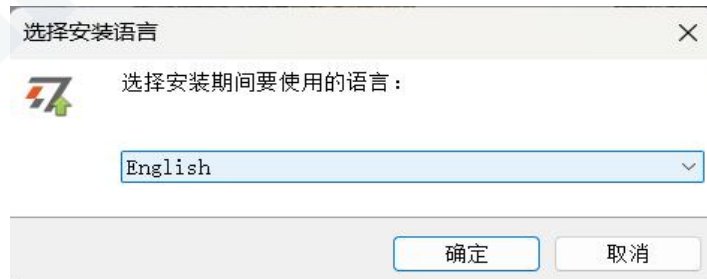

Step 2:

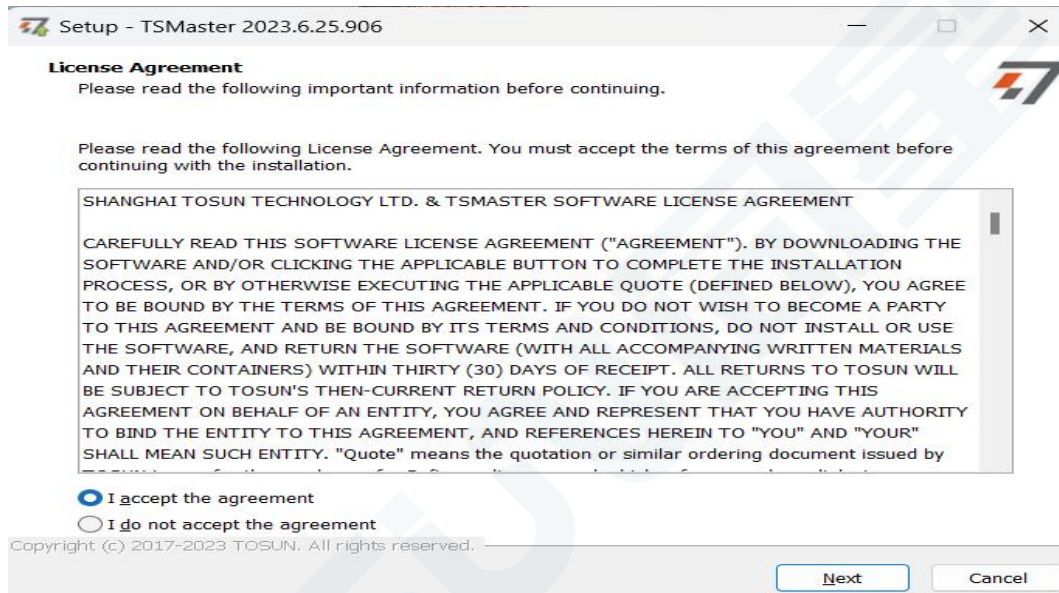

Step 3:

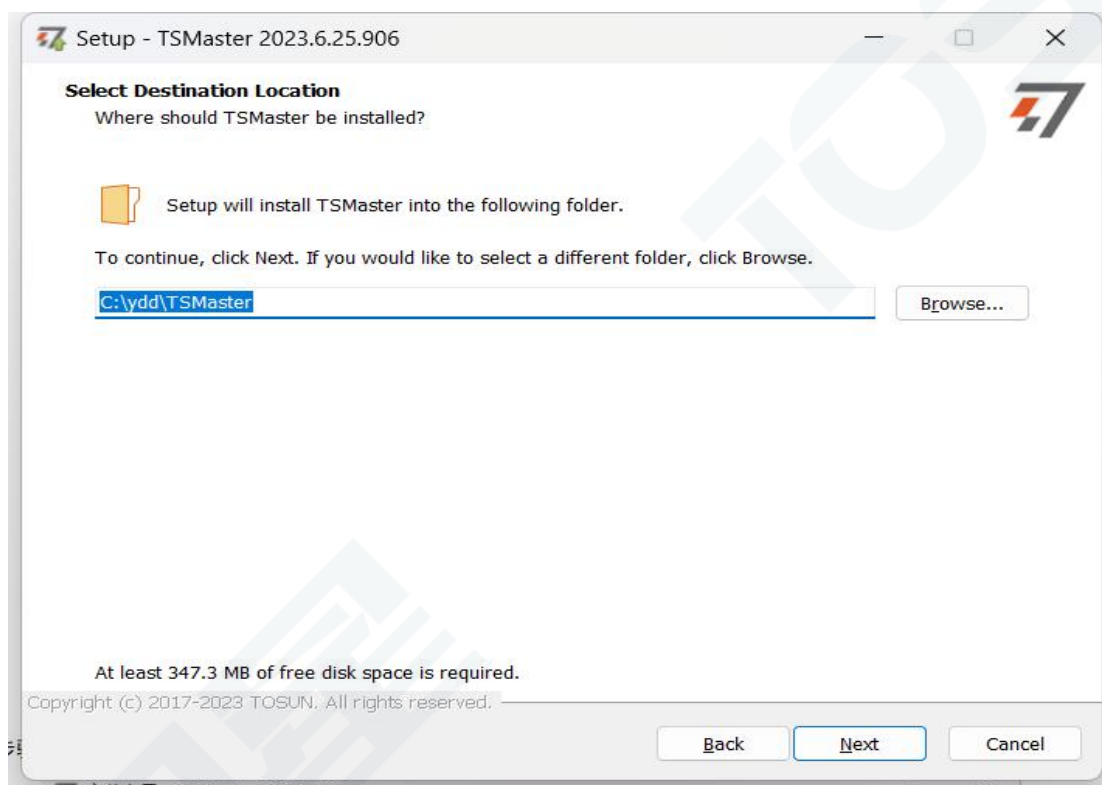

Step 4:

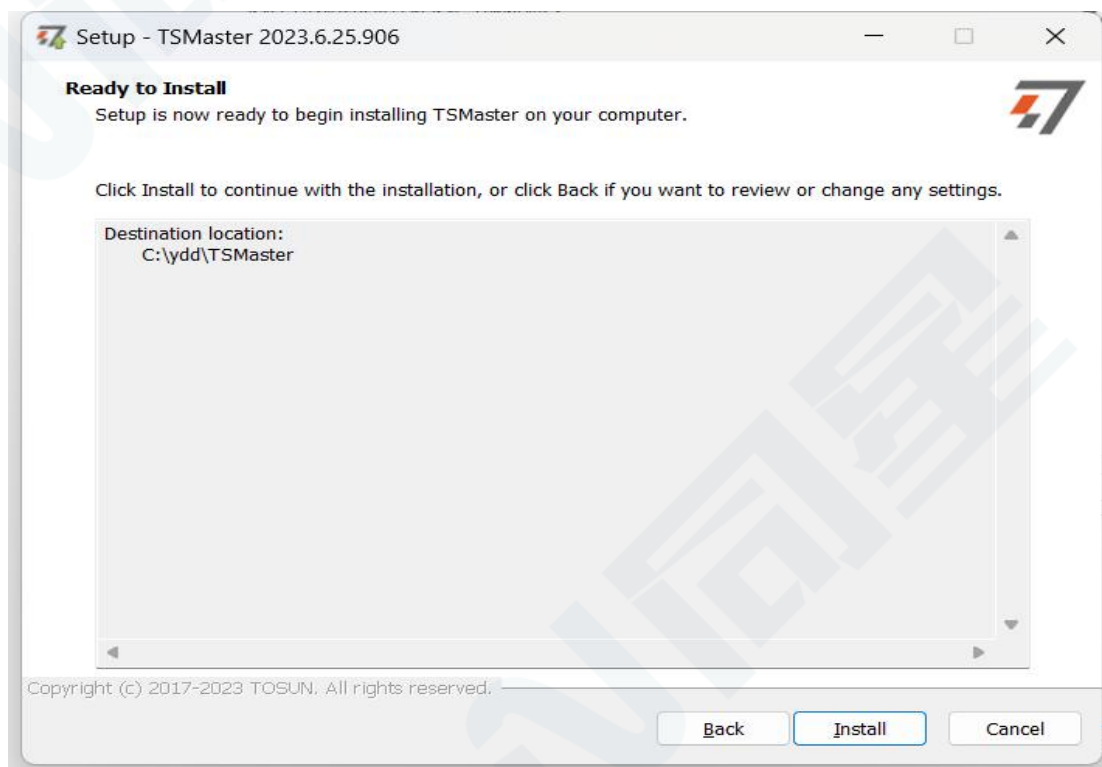

Complete installation:



3.2 Connect devices and configure channels

All TOSUN devices are drive-free, and can connect directly without download driver.

In TSMaster software interface: Click Hardware-click channel selection-drop-down box
Select number of channels-select hardware channel-click OK

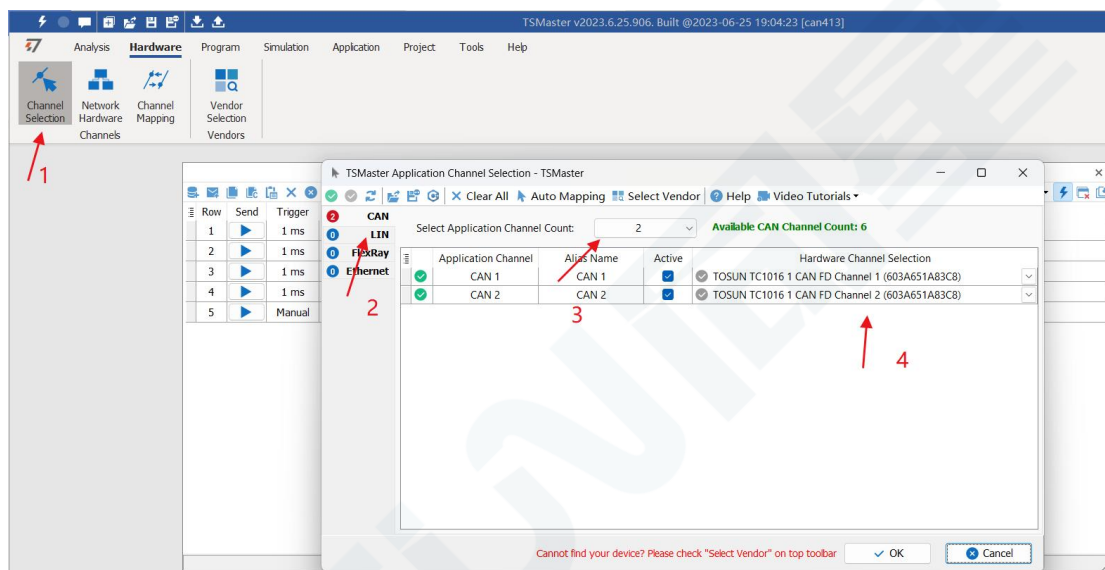

In the hardware configuration, the CAN / CAN FD protocol can be switched, and the baud rate and switch terminal resistance can be adjusted. After the configuration is completed, click application can take effect.

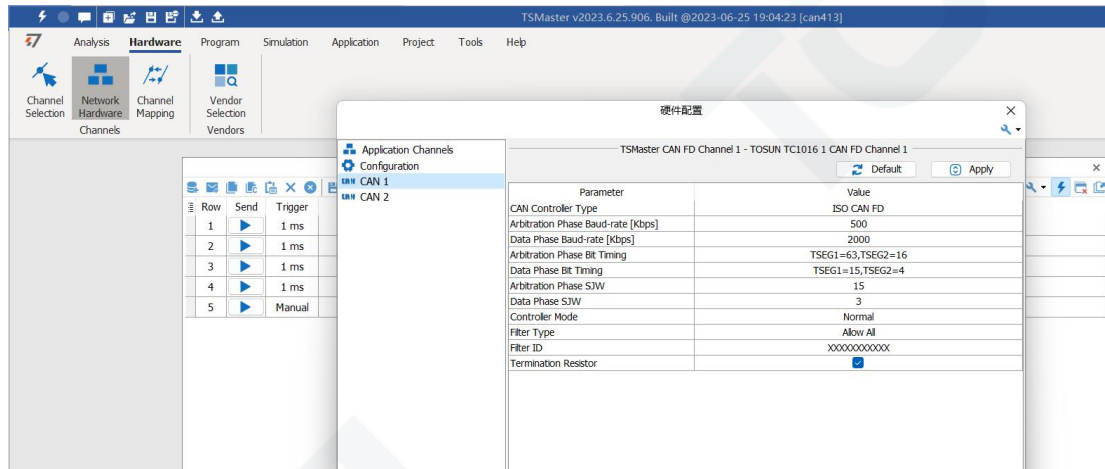

3.3 Message sending

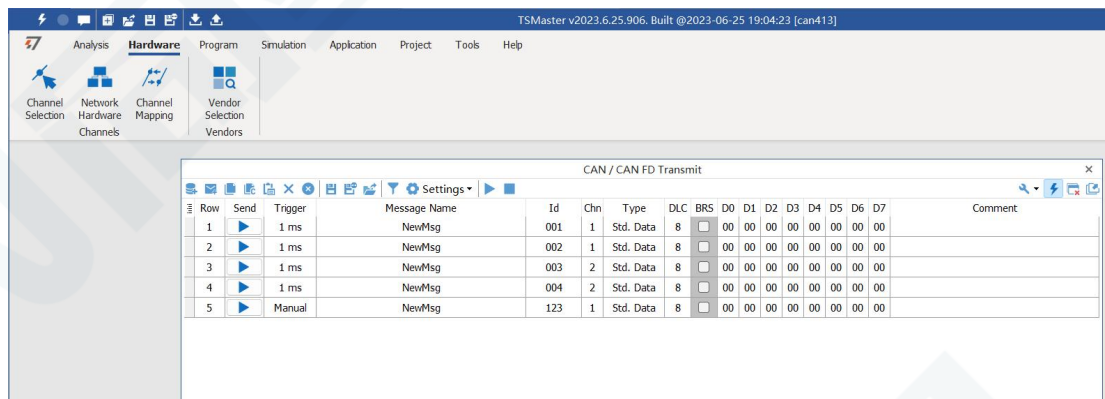

After the hardware connection is completed and the software is configured, the function of message sending can be realized:

operating steps:

- a. Message sending-Add a CAN / CAN FD message for sending
- b. Right mouse button to create a new original message / add a message from the database, and set the message name / identifier / channel, etc
- c. Message am trigger setting, manual trigger / cycle trigger, cycle trigger can set the sending cycle
- d. Message information right click can generate a C script to quickly add to the C small program for programming

The following is an example of the build-C script:

```

1 {
2 // [1] CAN 0x2 NewMsg
3 TCAN f0 = {0,0x1,8,0,0x2,0,{0x00, 0x00, 0x00, 0x00, 0x00, 0x00, 0x00, 0x00};
4 com.transmit_can_async(&f0);
5 app.wait(0, "");
6 }
7
8
    
```

Support for quick copy and paste to a C script to add send events:

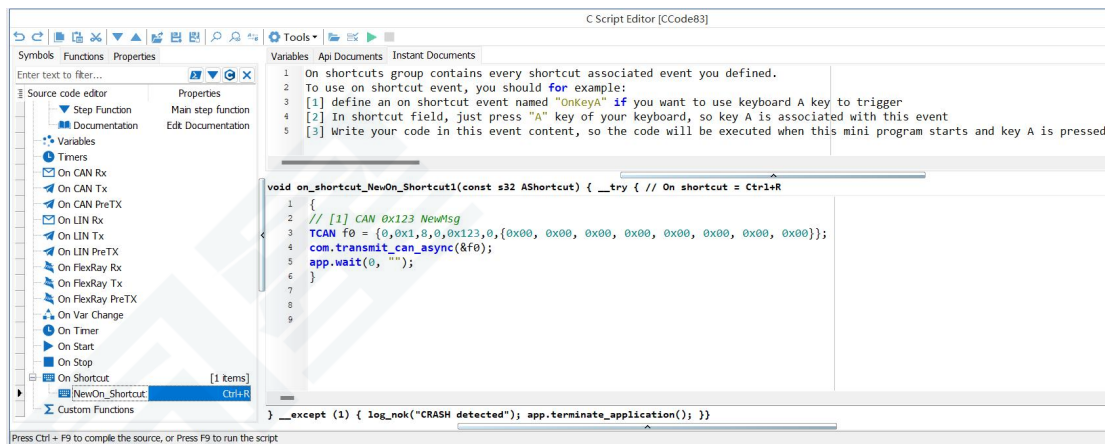

3.4 Help with documentation and video teaching

Various instructions and help manuals are provided in the TSMaster help bar.

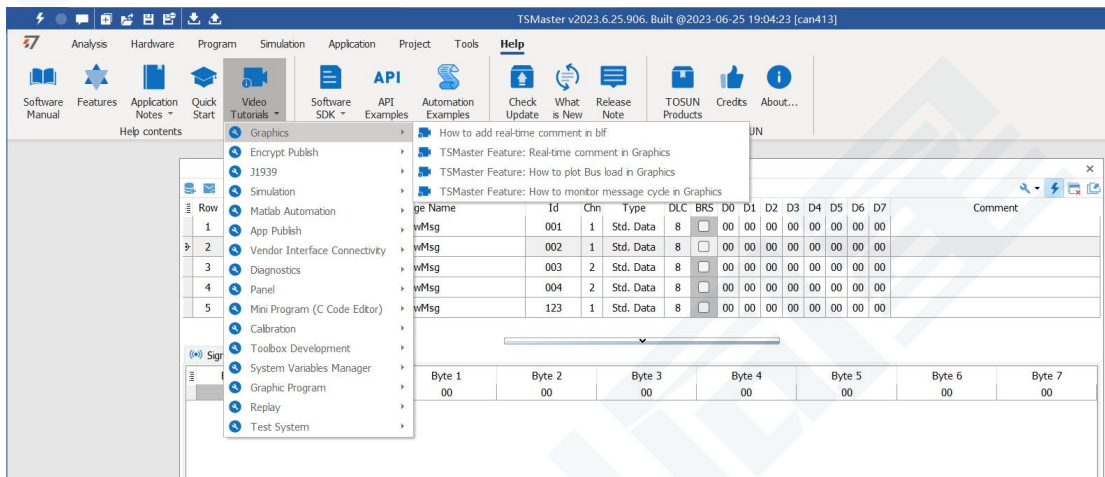

At the same time, a large number of teaching videos can enter B station

<http://space.bilibili.com/2042371333>, follow the tosun intelligent official number, watch all the teaching videos.

3.5 TSMaster API Secondary development

In the TSMaster help bar API routine, a variety of common language API is provided to facilitate users' secondary development. Efficient and easy-to-use secondary development functions that can support all kinds of development environments, such as C, Python, C #, Labview, etc.

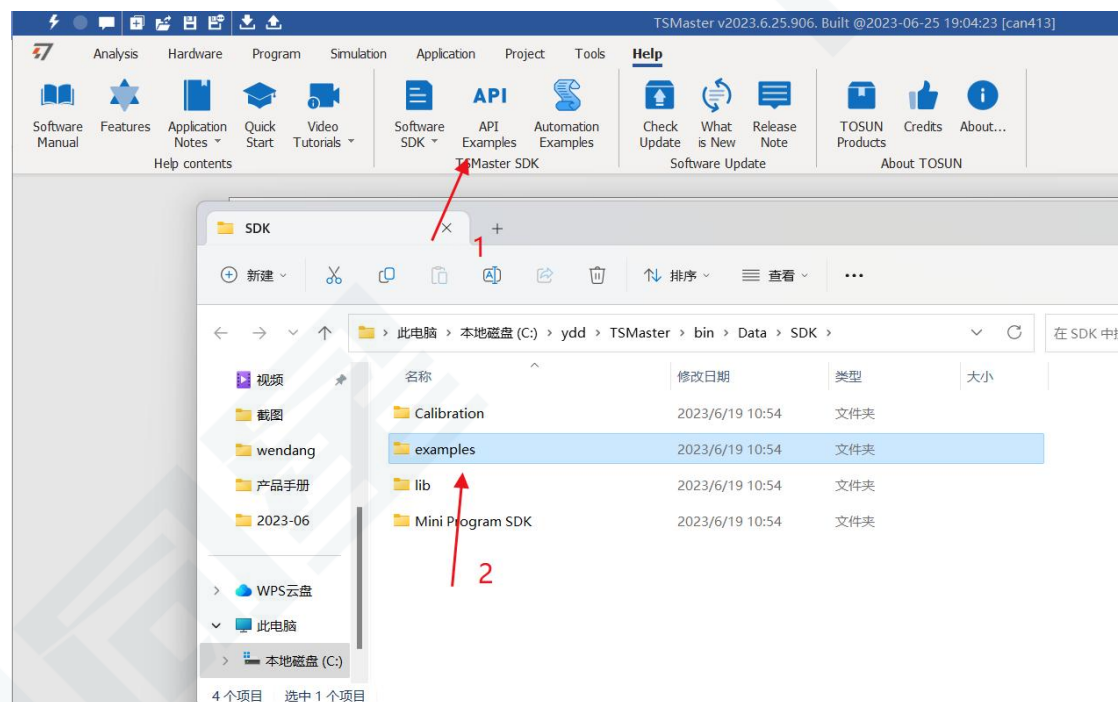

3.5.1 Python calls the dynamic library

Windows32-Position Python:

- (1) pip install TSMasterAPI
- (2) Using the TSMasterAPI form `TSMasterAPI import *` for
- (3) Example synchronous upload github, address: <https://github.com/sy950915/TSMasterAPI.git>

Windows64 bit Python / Li nux:

- (1) pip install libTSCANAPI
- (2) Using the TSMasterAPI form `libTSCANAPIimport *` for
- (3) Example synchronous upload github, address: <https://github.com/sy950915/libTSCANAPI.git>

3.5.2 C calls the dynamic library

(1) Include TSMaster in a file with a path of TSMaster \ bin \ Data \ SDK \ lib \ x86.h header file.

Such as: # include " TSMaster.h"

(2) Include TSMaster in a file with a path of TSMaster \ bin \ Data \ SDK \ lib \ x86. The lib file is connected to TSMaster.lib document.

In the C environment, add TSMaster to the Configuration Property connector input additional dependencies in the project property page.lib document.

3.5.3 Example of the calling of the interface

Windows, The Linux system provides the secondary development interface, easy to connect and use the equipment. The operation step are: select channel-generate C code-use C code / python code to call the interface. Take the code C as an example:

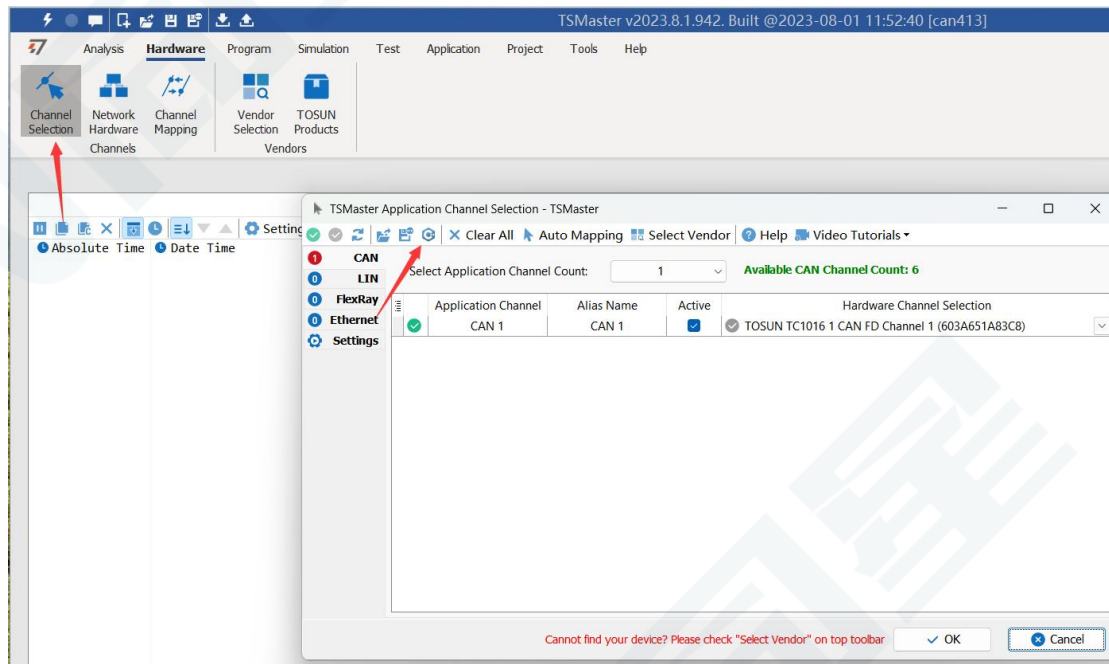

C Script Fragments:

7 C脚本片段

```

1  initialize_lib_tsmaster("TSMaster");
2  tsapp_set_can_channel_count(1);
3  tsapp_set_lin_channel_count(0);
4  tsapp_set_flexray_channel_count(0);
5  tsapp_set_ethernet_channel_count(0);
6
7  TLIBTSMapping m;
8
9  // TSMaster CAN FD 通道 1 - TOSUN TC1012 1 CAN FD 通道 1
10 m.init();
11 sprintf_s(m.FAppName, "%s", "TSMaster");
12 sprintf_s(m.FHWDeviceName, "%s", "TOSUN TC1012");
13 m.FAppChannelIndex = 0;
14 m.FAppChannelType = (TLIBApplicationChannelType)0;
15 m.FHWDeviceType = (TLIBBusToolDeviceType)3;
16 m.FHWDeviceSubType = 12;
17 m.FHWIndex = 0;
18 m.FHWChannelIndex = 0;
19 if (0 != tsapp_set_mapping(&m)) { /* handle error */ };
20
21 if (0 != tsapp_connect()){ /* handle error */ };
22
23 /* do your work here */
24
25 tsapp_disconnect();
26 finalize_lib_tsmaster();

```

C script call function description:

initialize _ lib _ tsmaster ("TSMaster");// TSMaster initialization function

Tsapp _ set _ can _ channel _ count (1);// Set the number of can channels

The tsapp _ set _ lin _ channel _ count (0);// Set the number of lin channels

The tsapp _ set _ flexray _ channel _ count (0);// Set the number of flexray channels

The tsapp _ set _ ethernet _ channel _ count (0);// Set the number of ethernet channels

TLIBTSMapping m; // Initialize the construct

// Set the TSMaster CAN FD channel 1-TOSUN TC1012 CAN FD channel 1 channel mapping

m. The init (); // initial construct m

sprintf_s(m. FAppName, "%s", "TSMaster");// Print the application name "TSMaster"

sprintf_s(m. FHWDeviceName, "%s", "TOSUN TC1012");// Print the hardware device name

```
m. FAppChannelIndex = 0; // Application channel index
m. FAppChannelType = (TLIBApplicationChannelType) 0; // Application channel type
m. FHWDDeviceType = (TLIBBusToolDeviceType) 3; // Hardware device type
m. FHWDDeviceSubType = 12; // corresponding parameters of hardware equipment *
m. FHWIndex = 0; // Hardware index
m. FHWChannelIndex = 0; // Hardware channel index
if (0 != Tsapp _ set _ mapping (& m)) { * handle error * /}; // If the return value is not equal
to 0 mapping failure
```

```
The tsapp _ disconnect(); // Disconnect the device
finalize _ lib _ tsmaster(); // Release the C script module
```

* Note: The corresponding parameters of the hardware equipment can be found in the TSMaster-Help-Software Development Package :
TSMasterAPI_Hardware_Map.pdf

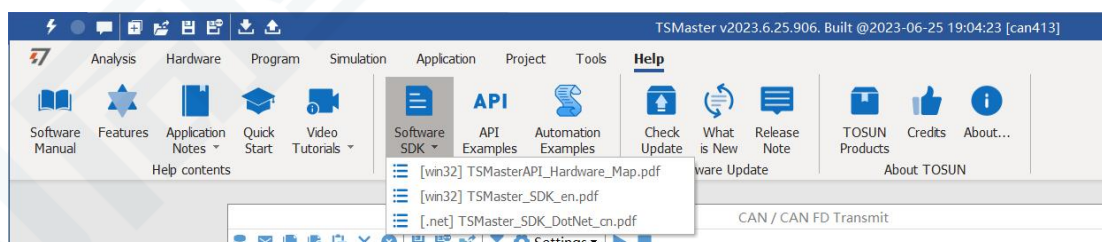

3.6 Sample Works

The example project provides a lot of Demo for user reference, greatly improving the user development efficiency.

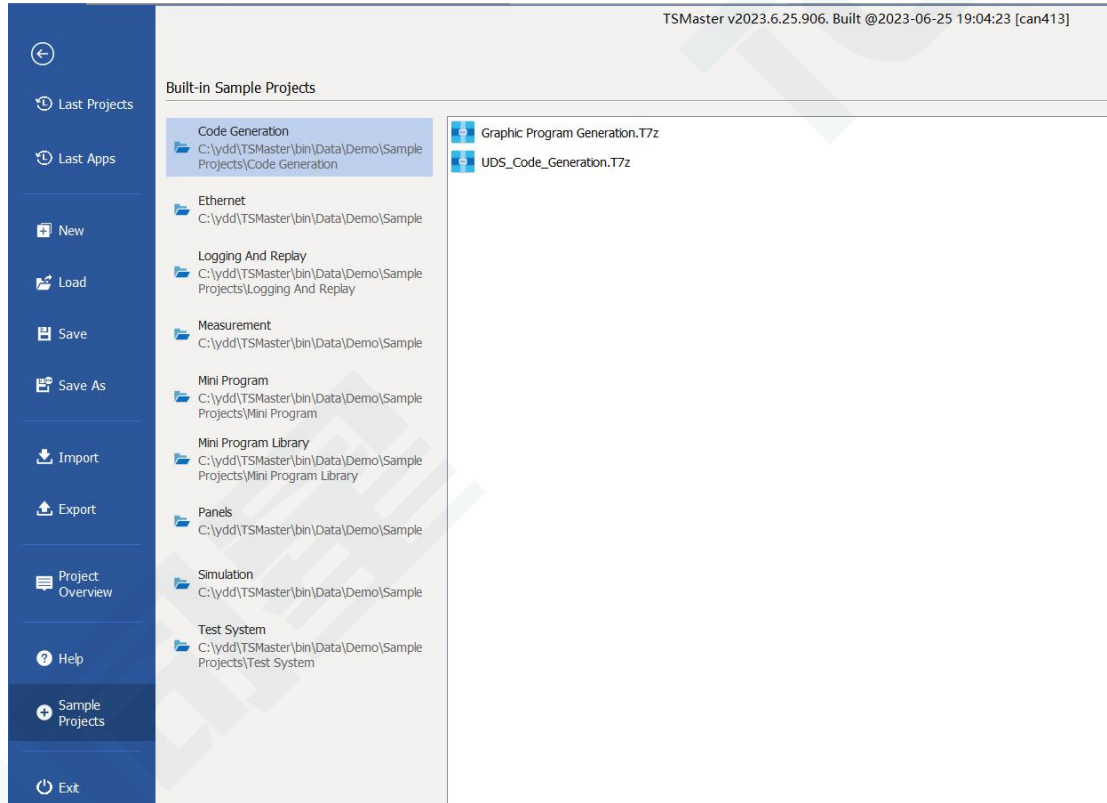

Sample project panel:

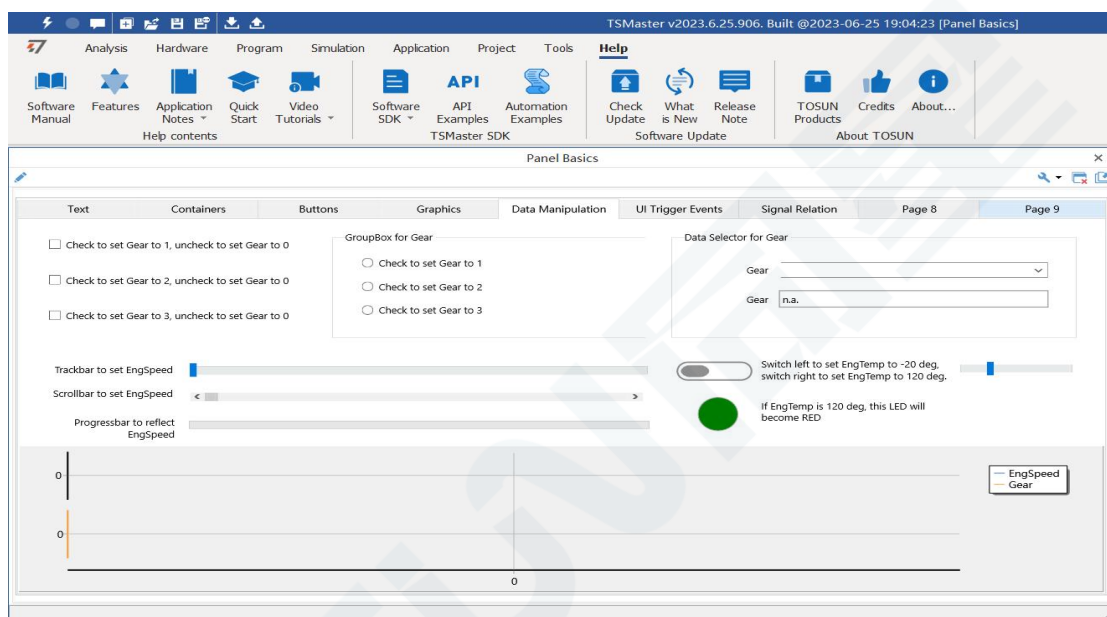

4. Inspection and maintenance

TC1012 The main electrical component is the semiconductor component, although it has a long life, it may accelerate aging in the incorrect environment, greatly reducing the life. Therefore, regular inspections should be conducted during the use of the equipment to ensure that the use environment maintains the required conditions. It is recommended to check it up at least once every 6 months to a year. Under adverse environmental conditions, more frequent examinations should be performed. In the table below, if you encounter problems during maintenance, read below to find the possible cause of the problem. If the problem is still not solved, please contact Shanghai TOSUN Intelligent Technology Co., LTD.

project	check up	standard	move about
power supply	Check the voltage fluctuation at the power supply side	7~18V DC	Use the voltmeter to check the source at the power supply input end. Take the necessary measures to make the voltage fluctuation within the range
surrounding environment	Check the ambient temperature (Including the internal temperature of the enclosed environment)	-40°C~+80°C	Use a thermometer to check the temperature and ensure that the ambient temperature remains within the allowable range
	Check ambient humidity (Including the internal humidity in the closed environment)	Without air conditioning, the relative humidity must be at 10%~90%	Use a humidity meter to check the humidity and ensure that the ambient humidity remains within the allowable range
	Check for the accumulation of dust, powder, salt, and metal debris	No accumulation	Clean and protect the equipment
	Check water, oil, or chemical spray collision into the device	No spray touched the device	If the cleaning and protection equipment is required
	Check for corrosive or	No easily	Check by smelling or using

	flammable gases in the equipment area	corrosive or flammable gases	a sensor
	Check the vibration and shock levels	The vibration and shock are within the specified limits	Install the liner or other shock absorber, if required
	Check the noise sources near the equipment	There are no significant noise signal source	Isolation equipment and noise sources or protection equipment
Install wiring	Check the compression connector in the external wiring	There is sufficient space between the connectors	Visual scopic inspection adjust if necessary
	Check for the damage to the external wiring	No damage	Visual inspection and replace wiring if necessary

5. Common questions and answers

5.1 The line is connected correctly but cannot communicate properly:

Solution: Check if the number of channels is set. If CAN Channel Count = 0, of course no online hardware cannot display. And the software is configured by default virtual channel, you need to select **the hardware real channel**.

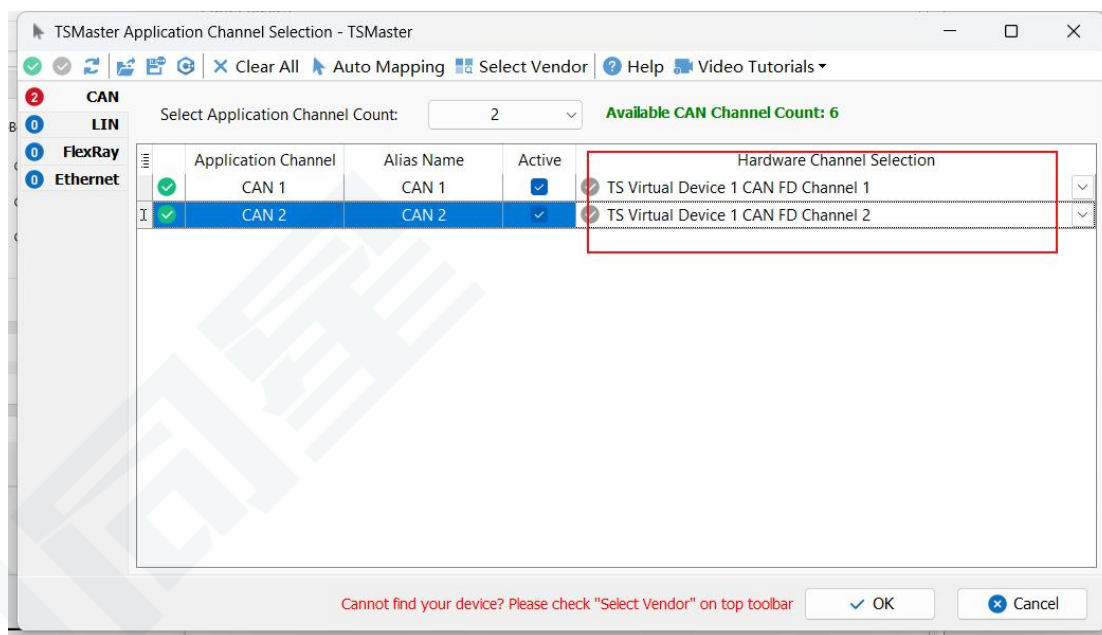

Automatically map or manually click to select the hardware real channel:

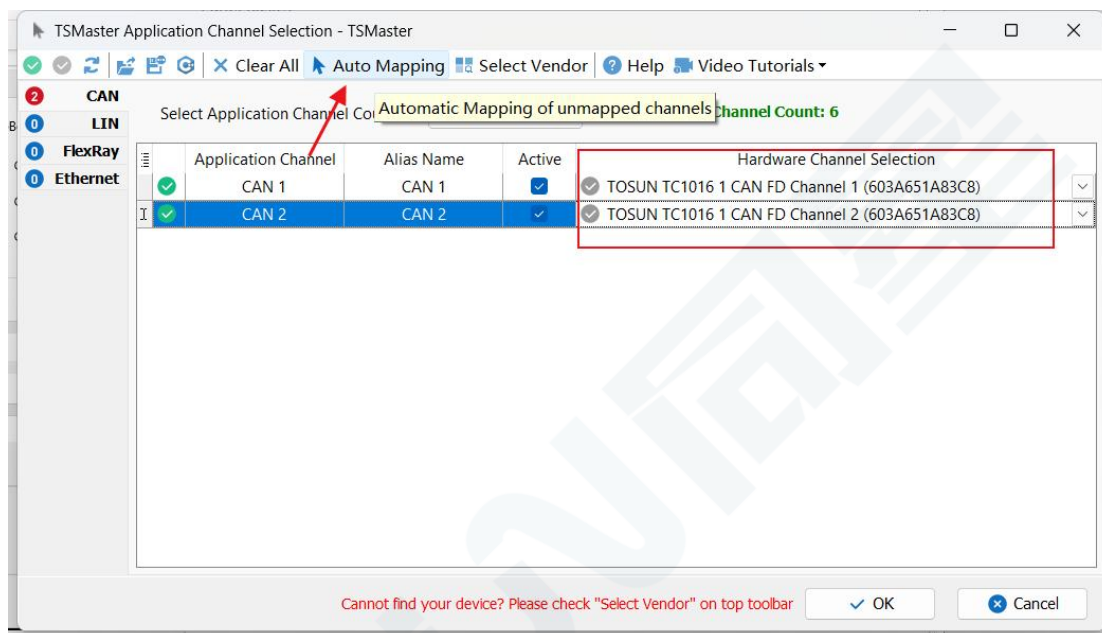

If the channel is selected correctly, it is necessary to ensure consistent port communication between the two channels, as shown in the figure below:

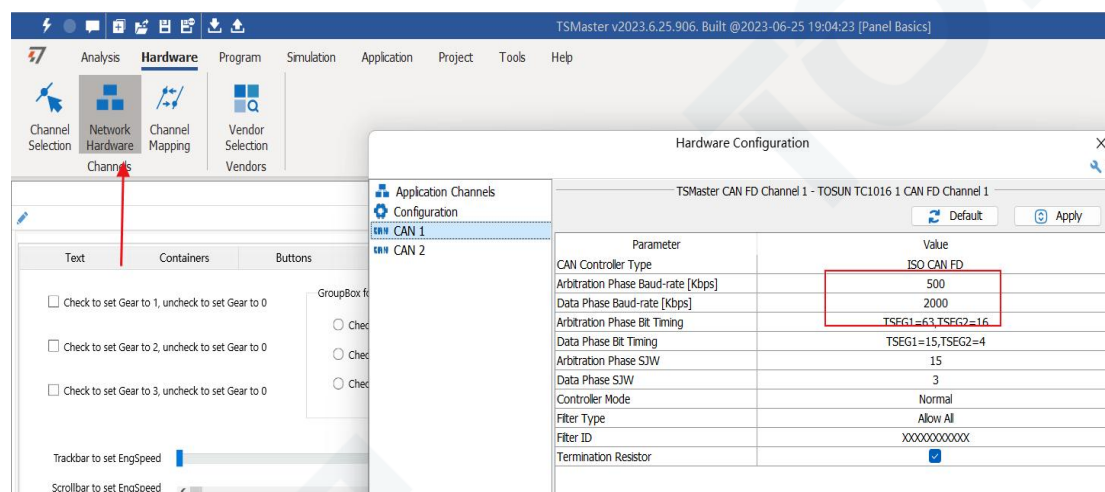

5.2 Inconvenient message observation and signal filtering:

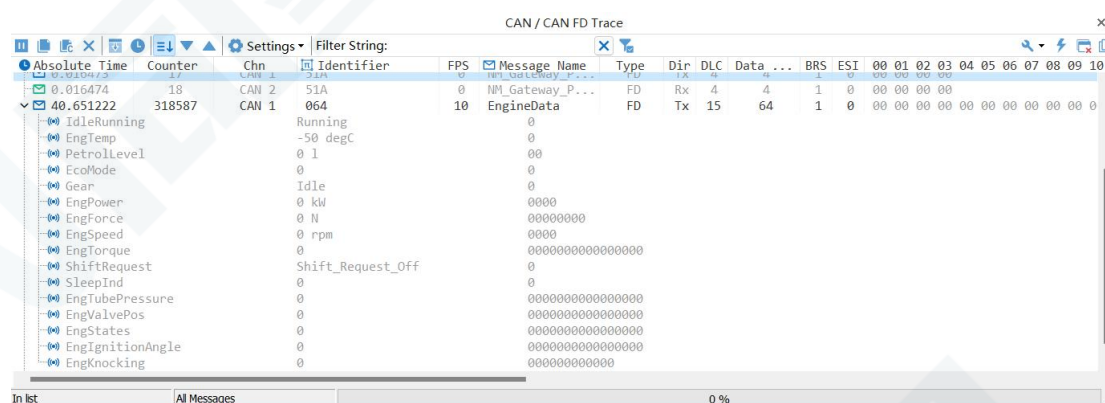

Solution: display in a fixed display or time order, expand or fold the signal display, and filter the string, click the following icon to operate:

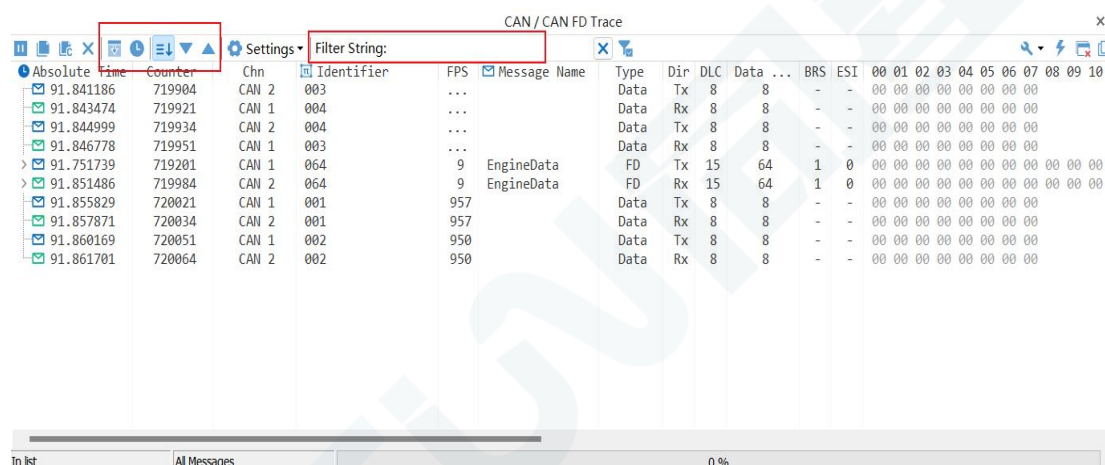

5.3 How to load the database:

Select the can / lin / flexray database, click the upper left corner icon to add the database file, or drag the file directly into this window to be automatically loaded, and then click the left channel to associate the database.

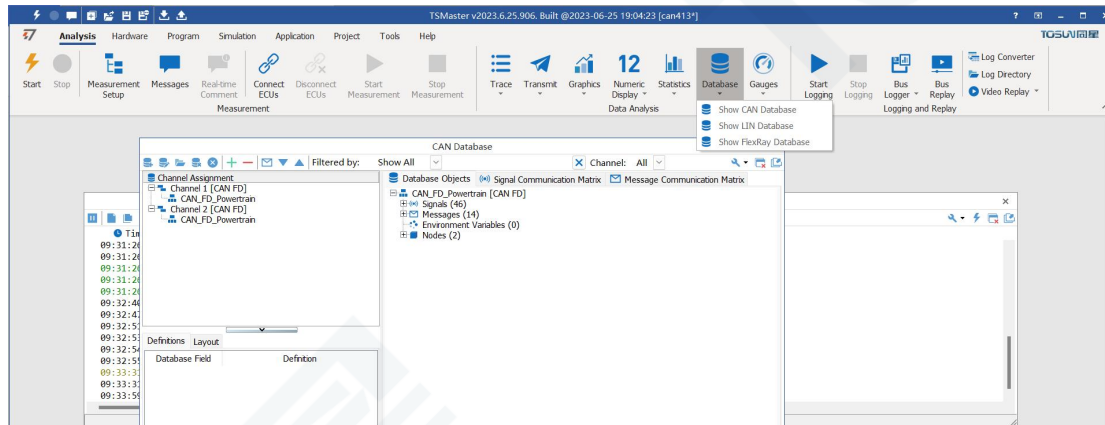

5.4 How to automatically record the message messages:

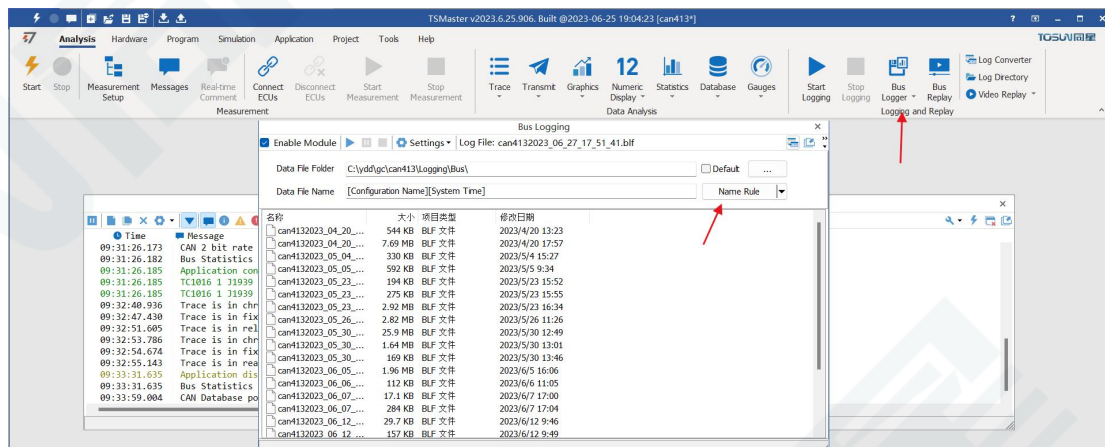

operating steps:

- Analysis- -bus record
- Add a name rule to distinguish between different save files
- Add the self-start function
- Start the record

5.5 How to replay messages (offline and online playback):

operating steps:

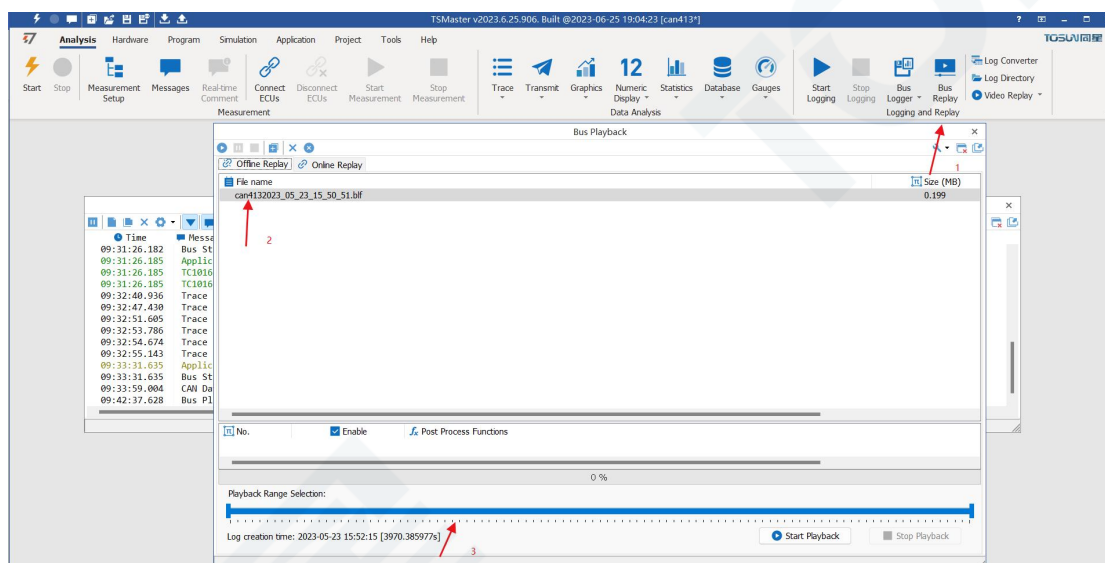

a. Bus playback

b. Offline playback, add the need to be played packets, can drag and drop file add directly

c. **Select the range of message playback.** Since the number of message display window is limited, you can choose the time period required for the message

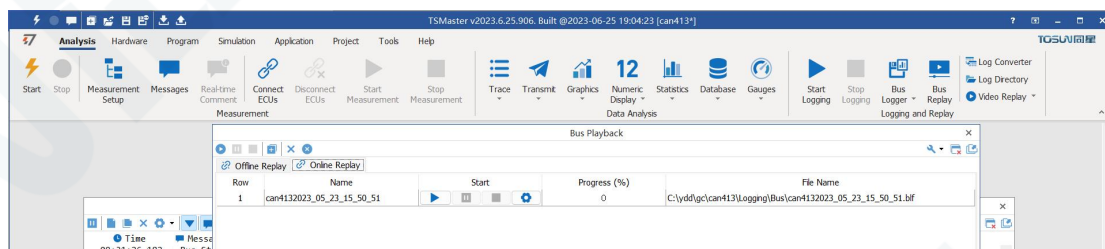

d. Bus playback-online playback-add recording files

e. **Online playback can playback the message according to the acquisition time stamp,**and set the playback data

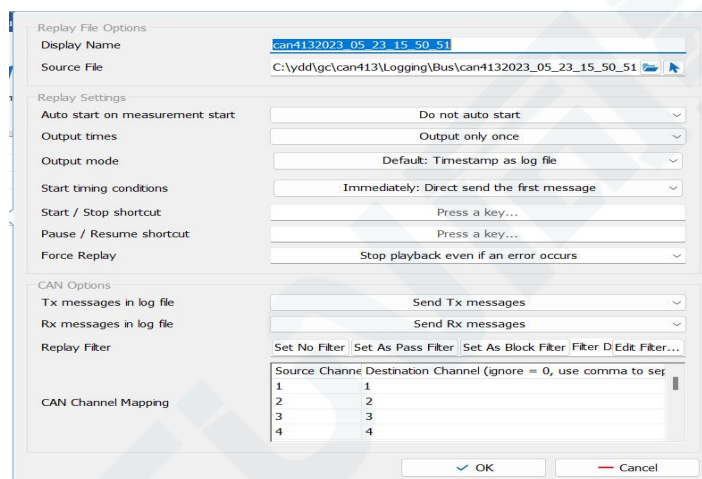

6. Appendix

6.1 CAN 2.0 Standard Frame:

The CAN standard frame information is 11 bytes, consisting of two parts: information and data parts. The first 3 bytes are for the information section.

	7	6	5	4	3	2	1	0
Bytes 1	FF	RTR	x	x	DLC (Data Length)			
Bytes 2	(Message identification code) ID.10-ID.3							
Bytes 3	ID.2-ID.0			x	x	x	x	x
Bytes 4	Data 1							
Bytes 5	Data 2							
Bytes 6	Data 3							
Bytes 7	Data 4							
Bytes 8	Data 5							
Bytes 9	Data 6							
Bytes 10	Data 7							
Bytes 11	Data 8							

Byte 1 is the frame information. The 7th bit (FF) represents the frame format, in the standard frame, FF=0; the 6th bit (RTR) represents the type of frame, RTR = 0 is a data frame, RTR = 1 is a remote frame; the DLC represents the actual length of data at the data frame.

Bytes 2 and 3 are message identification codes, and 11 bits are valid.

Bytes 4~11 is actual data of data frame, remote frame is invalid.

6.2 CAN 2.0 Expansion Frame:

CAN extended frame information for 13 bytes, including two parts, information and data parts. The first 5 bytes are for the information section.

	7	6	5	4	3	2	1	0
Bytes 1	FF	RTR	x	x	DLC (Data Length)			
Bytes 2	(Message identification code) ID.28-ID.21							
Bytes 3	ID.20-ID.13							
Bytes 4	ID.12-ID.5							
Bytes 5	ID.4-ID.0				x	x	x	
Bytes 6	Data 1							
Bytes 7	Data 2							
Bytes 8	Data 3							
Bytes 9	Data 4							
Bytes 10	Data 5							
Bytes 11	Data 6							
Bytes 12	Data 7							
Bytes 13	Data 8							

Byte 1 is the frame information. The 7th (FF) indicates the frame format, FF = 1; the 6th (RTR)

It represents the type of frame, RTR = 0 as a data frame and RTR = 1 as a remote frame; DLC represents the actual data length at the data frame.

Byte 2~5 is the message identification code, and its high 29 bits is valid.

Bytes 6~13 is actual data of data frame, remote frame is invalid.

6.3 matters need attention

- ① Connect the lines to avoid short circuit.
- ② Before using the equipment, please carefully check the pin information in the product manual.
- ③ During the operation of the equipment, be sure to connect the power cord correctly and avoid plugging and unplugging.
- ④ Attention! Damage caused by electrostatic discharge (ESD).

7. Disclaimer

Shanghai TOSUN Technology , LTD. based on the principle of providing better service for users, will present detailed and accurate product information for users as much as possible in this manual. However, since the content of this manual has a certain timeliness, TOSUN Technology cannot fully guarantee the timeliness and applicability of the document in any period of time. TOSUN Technology has the right to update the contents of this manual without notice. In order to get the latest version of the information, please visit the official website of TOSUN Technology regularly or contact the staff of TOSUN Technology regularly. Thank you for your tolerance and support!



汽车电子工具链，国产领导品牌

同星智能成立于2017年，一直专注于研发国产自主可控的汽车电子基础工具链产品，也是该领域国产领导品牌。

同星智能的核心软件TSMaster及配套硬件设备，具备嵌入式代码生成、汽车总线分析、仿真、测试及诊断、标定等核心功能，覆盖了汽车整车及零部件研发、测试、生产、试验、售后全流程。

全球企业用户超4000家，用户覆盖：汽车整车厂、零部件供应商、芯片厂商、设备/服务供应商、工程机械、航空航天及舰船军工等领域。



扫码关注
获取软件下载链接

软件

- UDS诊断
- ECU刷写
- CCP/XCP标定
- 嵌入式代码生成
- 应用发布/加密发布
- 记录与回放
- 图形化编程
- 剩余总线仿真
- C/Python脚本
- 总线监控/发送
- SOMEIP和DoIP

硬件

- 1/2/4/8/12通道CAN FD/CAN转USB工具
- 1/2/6通道LIN转USB工具
- 10通道CAN FD/CAN转以太网工具
- 多通道Flexray/CAN FD转USB工具
- 多通道车载以太网/CAN FD转USB工具
- 车载以太网介质转换工具(T1转Tx)
- 多通道CAN FD/Ethernet/LIN记录仪



解决方案

- EOL测试设备
- FCT测试设备
- 汽车“四门两盖”试验解决方案
- 线控底盘测试解决方案
- 电机性能/耐久试验解决方案
- 新能源产线设备解决方案
- 总线一致性测试解决方案
- 信息安全解决方案